

Tinius Olsen

Rockwell and Universal Hardness Testers FH-2 Series

KEY FEATURES

- Load cell, force feedback, closed loop system
- Unparalleled rigidity
- Unmatched gauge repeatability and reproducibility
- Load range 1kgf (2.2 lbf) up to 250 kgf (550 lbf)
- Complies with all applicable EN/ISO, ASTM and JIS standards
- Shape correction settings for curved surfaces
- Optical depth measuring system (Rockwell, HBT, HVT, Ball indentation for plastics ISO 2039/1)
- Sophisticated controller with high definition touch screen control
- High end video based hardness testing firmware, including CCD camera, automatic indent measurement, high definition optical magnification of indent system, conversion to other hardness scales, test data and image storage, statistic results storage, and operation of optional Jominy stage, X-Y stage operation
- Password and user level access system
- Easy calibration function
- Standard nose cone clamping attachment
- Work piece sliding table (FH-2-1 model)
- Accommodation of large work pieces
- Motorized spindle (optional)

Fig. 1. Model FH-2-0
with LCD screen



Fig. 2. FH-2-1 with built-on microscope

Technical Specifications

Load application	Load cell, force feedback, closed loop system
Hardness scales FH-2-0	Rockwell / Superficial Rockwell, HVT, HBT, and Ball indentation for plastics to ISO 2039/1
Hardness scales FH-2-1	Rockwell / Superficial Rockwell, Brinell, Vickers, HVT, HBT, and Ball indentation for plastics to ISO 2039/1
Load range FH-2-0 and FH-2-1	1 kgf to 250 kgf (2.2 lbf to 551 lbf)
Test loads	1, 2, 2.5, 3, 5, 10, 15, 15.625, 20, 30, 31.25, 45, 50, 60, 62.5, 100, 125, 150, 187.5, 250 kgf (2.2, 4.4, 5.5, 5.51, 6.6, 11, 22, 33, 34, 44, 66, 69, 79, 110, 132, 138, 220, 276, 331, 413, 551 lbf)
Vickers test range (FH-2-1)	HV1, HV 2, 3, 5, 10, 20, 30, 50, 100, 120 kgf (4.4, 6.6, 22, 44, 66, 110, 220 lbf); HVT 50, 100 kgf (110, 220 lbf)
Brinell test range (FH-2-1)	HB1/2.5, 5, 10, 31.25 kgf; (5.5, 11, 22, 69 lbf) HB2.5/6.25, 15.625, 31.25, 62.5, 187.5 kgf (14, 34, 69, 138, 413 lbf); HB5/25, 62.5, 125, 250 kgf; (55, 138, 276 lbf) HB10/100, 250 kgf; (220 lbf) HBT2.5/62.5, 187.5 kgf; (138, 413 lbf) HBT5/250 kgf (551 lbf)
Rockwell scales	A, B, C, D, E, F, G, H, K, L, M, P, R, S, V
Rockwell Superficial scales	15N, 30N, 45N, 15T, 30T, 45T, 15W, 30W, 45W, 15X, 30X, 45X, 15Y, 30Y, 45Y
Plastic Ball indentation	Complies with ISO 2039/1
Scale resolution (depth)	0.1 micron
Display	Large high definition industrial touch screen can also be operated by mouse and keyboard
Standards	Complies with, or exceeds, EN/ISO, ASTM and JIS standards
Test cycles	Fully automatic, Load, Dwell, Unload
Dwell time	1- 99 seconds
Data output/connectivity	USB-2 (6) RJ-45 LAN, W-LAN, (RS-232)
Specimen accommodation	Height 300 mm (11.81") Throat 200 mm (7.87")
Weight	110 kg (243 lbs) FH-2-1; 103kg (226lb) FH-2-0
Operating Temperature Range	10° to 35°C (50° to 95°F)
Operating Humidity Range	10% to 90% non-condensing
Power Supply	110 to 240V AC , 50/60Hz, single phase

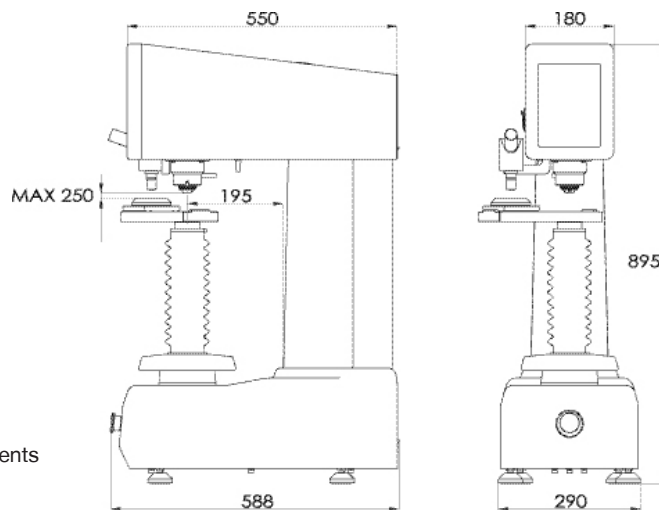

Fig. 2. FH-2-1
All measurements are in mm

Contact Your Local Representative:

C&M / COMPONENTS & MACHINES e.U.
Steinbachstrasse 133
3001 Mauerbach
Austria
www.cm-tech.at

STANDARD ACCESSORIES

- Built-on microscope with HD CCD camera, LED light for dark field illumination (FH-2-1)
- Objectives for 2.5x, 5x and 10x magnification (FH-2-1)
- Sliding testing table (FH-2-1)
- Flat anvil, hardened, ø60 mm (2.36")
- Testing table, hardened, ø180 mm (7.09")
- V-anvil hardened ø80 mm (3.15")
- Fuse 3A slow (2 pcs)
- Power cable
- Factory calibration certificate
- Installation and user manual

OPTIONAL ACCESSORIES

- Certified hardness test blocks
- Certified indentors
- Knoop hardness testing scale (FH-2-1)
- Long indentors
- Goose neck indenter holder
- Large testing table 350 x 250 mm (13.78 X 10") with T-slot and spindle adaptor
- Custom testing tables
- Precision vices, V-blocks, and special clamps
- Manual X-Y stage, 100x60mm, micrometer travel 25x25mm
- Motorized Y stage for Jominy testing
- Motorized X-Y for pattern testing
- Motorized spindle
- Precision vise for small parts, jaw width 36mm
- Precision vise for small parts, jaw width 45mm
- Precision vise for small parts, jaw width 75mm
- LED ring light (for FH-2-1)



Horsham, PA USA

Redhill, Surrey UK

Noida, UP India

info@tinilusolsen.com
www.TinilusOlsen.com
www.testinghardness.com